



Standard Practice for Storage and Use of Liquefied Petroleum Gases (LPG) in Sample Cylinders for LPG Test Methods¹

This standard is issued under the fixed designation D6849; the number immediately following the designation indicates the year of original adoption or, in the case of revision, the year of last revision. A number in parentheses indicates the year of last reapproval. A superscript epsilon (ϵ) indicates an editorial change since the last revision or reapproval.

1. Scope*

1.1 This practice covers information for the storage and use of LPG samples in standard cylinders of the type used in sampling method, Practice [D1265](#) and floating piston cylinders used in sampling method, Practice [D3700](#).

1.2 This practice is especially applicable when the LPG sample is used as a quality control (QC) reference material for LPG test methods, such as gas chromatography (GC) analysis (Test Method [D2163](#)) or vapor pressure (Test Method [D6897](#)) that use only a few mL per test, since relatively small portable Department of Transportation (DOT) cylinders (for example, 20 lb common barbecue cylinders) can be used. This practice can be applied to other test methods. However, test methods that require a large amount of sample per test (for example, manual vapor pressure Test Method [D1267](#)) will require QC volumes in excess of 1000 L if stored in standard DOT cylinders or American Society of Mechanical Engineers (ASME) vessels.

2. Referenced Documents

2.1 ASTM Standards:²

- [D1265 Practice for Sampling Liquefied Petroleum \(LP\) Gases, Manual Method](#)
- [D1267 Test Method for Gage Vapor Pressure of Liquefied Petroleum \(LP\) Gases \(LP-Gas Method\)](#)
- [D2163 Test Method for Determination of Hydrocarbons in Liquefied Petroleum \(LP\) Gases and Propane/Propene Mixtures by Gas Chromatography](#)
- [D3700 Practice for Obtaining LPG Samples Using a Floating Piston Cylinder](#)
- [D6299 Practice for Applying Statistical Quality Assurance and Control Charting Techniques to Evaluate Analytical](#)

¹ This practice is under the jurisdiction of ASTM Committee [D02](#) on Petroleum Products, Liquid Fuels, and Lubricants and is the direct responsibility of Subcommittee [D02.08](#) on Volatility.

Current edition approved June 15, 2013. Published July 2013. Originally approved in 2002. Last previous edition approved in 2012 as [D6849-02](#) (2012). DOI: 10.1520/D6849-13.

² For referenced ASTM standards, visit the ASTM website, www.astm.org, or contact ASTM Customer Service at service@astm.org. For *Annual Book of ASTM Standards* volume information, refer to the standard's Document Summary page on the ASTM website.

Measurement System Performance

[D6897 Test Method for Vapor Pressure of Liquefied Petroleum Gases \(LPG\) \(Expansion Method\)](#)

3. Terminology

3.1 Definitions:

3.1.1 *floating piston cylinder (FPC), n*—high-pressure sample container with a free-floating internal piston that effectively divides the container into two separate compartments.

3.1.1.1 *Discussion*—A floating piston cylinder is used to collect a sample of liquid under pressure without the formation of a gaseous phase which can result in changes in the composition of the liquid sample.

3.1.2 *high-pressure sample cylinder, n*—a container used for storage and transportation of a sample obtained at pressures above atmospheric pressure.

3.1.2.1 *Discussion*—This type of sample cylinder, sometimes called a 'standard 80 % fill cylinder', when used for LPG typically contains both liquid and vapor phase material.

3.1.3 *liquefied petroleum gas, (LP Gas, LPG), n*—a narrow boiling range mixture of hydrocarbons consisting of propane, propylene, butanes and butylenes, individually or in specified combinations, with limited amounts of other hydrocarbons and naturally occurring non-hydrocarbons.

3.1.3.1 *Discussion*—LPG is typically maintained in a liquid state by containing it within a closed container or storage tank that can withstand the vapor pressure of the LPG at ambient temperature, or at a low temperature in refrigerated storage.

3.1.4 *maximum fill volume (reduced fill volume), n*—the volume of a container that may be safely occupied by the liquid sample, usually expressed as a percentage of the total capacity.

3.1.4.1 *Discussion*—Some regulatory agencies use the expressions 'maximum fill density' and 'reduced fill density.'

4. Summary of Practice

4.1 This practice provides information for the design and operation of LPG sample storage cylinders taking into account properties of LPG and types of cylinders in common use for storage of LPG.

*A Summary of Changes section appears at the end of this standard

4.2 This practice provides additional guidelines to Practice D6299 to determine the minimum volume of LPG sample material required, when used as a QC reference material.

5. Significance and Use

5.1 LPG samples can change composition during storage and use from preferential vaporization of lighter (lower molecular weight) hydrocarbon components, dissolved inert gases (N₂, Ar, He, and so forth) and other dissolved gases/liquids (NH₃, CO₂, H₂S, H₂O, etc.). Careful selection of cylinder type, cylinder volume, and use of inert gas for pressurizing cylinders is required to ensure that composition changes are small enough to maintain the integrity of LPG when used as a QC reference material for various LPG test methods.

5.2 Monitoring of ongoing precision and bias on QC materials using control chart techniques in accordance with Practice D6299 can be used to establish the need for calibration or maintenance.

6. Reference Materials

6.1 The LPG QC reference material should have a vapor pressure and composition in the range of the samples regularly tested by the equipment. This is particularly important for LPG/natural gas liquid (NGL) mixtures near the critical temperature, as these liquids have large thermal and pressure expansion coefficients.

6.2 LPG QC reference materials should be stored in an environment suitable for long term storage without significant sample degradation for the test(s) being performed.

NOTE 1—As an example, evidence of a long term shift or bias in the LPG QC reference material results obtained relative to the established statistical control limits and average value determined for the test initially, may indicate that the composition of the LPG QC reference material has significantly degraded or changed over time. An investigation should be conducted to determine if the long term stability of the QC reference material is the cause for the out-of-control situation.

7. Use of Floating Piston Cylinders for LPG Samples

7.1 Minimum LPG sample volume can be determined in accordance with Practice D6299.

NOTE 2—Estimating the minimum LPG sample volume needed includes such things as the sample volume needed to conduct the appropriate test(s) and the number of analytical measurements that are expected to be made over the intended period of use.

7.2 Floating piston cylinders (see Fig. 1) are preferred for LPG sample materials for tests involving accurate determination of light gases.

7.3 Excessive inert gas pressure should be avoided for long term storage of vapor pressure QC or calibrant materials in floating piston cylinders. Leakage of inert gas past worn or damaged floating piston seals can cause an increase in dissolved gas concentration and vapor pressure of the QC sample material.

8. Use of Standard 80 % Fill Cylinders for LPG QC Materials

8.1 Common 80 % filled storage tanks or cylinders can be used for LPG QC materials provided that the QC material batch volume is sufficiently large to avoid adverse short term vaporization effects.

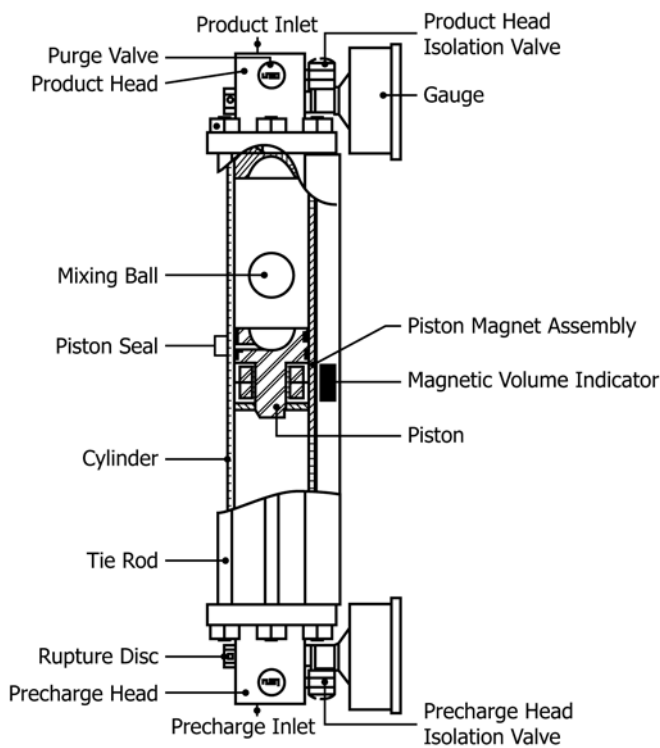

FIG. 1 Typical Floating Piston Cylinder (FPC)

8.2 The total initial volume and the minimum unused volume of QC materials stored in standard 80 % fill cylinders must be controlled to ensure that in the short term, composition is constant relative to the precision of the test method.

8.2.1 As liquid is withdrawn from LPG cylinders, a small amount of the remaining liquid must vaporize to replace the volume. This results in a small, but predictable, change in composition and vapor pressure from preferential vaporization of lighter components from the remaining liquid. The composition and vapor pressure changes are known to be approximately linear at low vapor to liquid (V/L) ratios. These changes accelerate and become more significant as the remaining volume of liquid decreases and the cylinder approaches empty. However, if the initial volume is sufficiently large, and the final V/L ratio is limited, the change will occur very slowly over time, and the material is still suitable as a QC. In the short term, the composition is essentially constant relative to the precision of the method.

8.2.2 In the long run, the control limits can be periodically adjusted to compensate for any long-term trend, or the charted response can be compensated for the long-term trend using historical data, or equation of state calculations based on cylinder weight or volume. Consult a statistician for appropriate techniques to develop a prediction model for the long-term trend.

8.2.3 Operation between the 80 % and 20 % fill levels is recommended to satisfy safety requirements and to limit the V/L ratio from 0.25 (1:4) at 80 % liquid filled up to 4 (4:1) at 20 % filled. The cylinder must be re-filled when the liquid level drops below the 20 % level and no further liquid can be withdrawn (see 8.2). This guards against excessive changes in concentration of the remaining QC liquid as would occur with